

Constant, Off-time, Buck-based, LED Drivers Using the HV9910B

Constant frequency, peak current controlled buck converters (Fig. 1) are an excellent choice for driving LEDs for a number of reasons:

- ▶ Reasonable regulation of LED current over wide variations in input and output voltages.
- ▶ Simple to design as no feedback compensation is required.
- ▶ PWM dimming response of the converters is almost instantaneous.

However, peak current controlled buck converters go into sub-harmonic oscillations at duty cycles over 50%. These oscillations cause the average output current to drop, while the output ripple current increases. The only way to avoid these problems is by adding slope compensation circuitry externally. The slope compensation adds an upward slope on to the current sense signal and the converter can be stabilized by varying the slope of the added ramp (Fig. 2). This added ramp causes an error between the sensed current (as seen at the CS pin of the HV9910B) and the actual LED current.

Although this error can be compensated for by changing the sensed resistor appropriately, the converter's rejection of the input and output voltage variations will be significantly degraded. Thus, changing the input or output voltage will significantly change the LED current, without additional feedback circuitry for regulating the LED current. This makes the peak current controlled buck converter practically useless for cases where the input voltage is less than twice the output voltage.

This problem can be overcome by changing the control method to a constant off-time operation. In this case, the off-time is fixed by design, the on-time is based on the current sense signal and the switching time-period adjusts to be equal to the on-time plus the off-time. This change will allow the converter to work with greater than 50% duty cycles and still have the advantages of the peak current controlled buck converter given above.

The information in this Application Note also applies to the Supertex HV9910.

Fig. 1. Constant Frequency, Peak Current Controlled LED Driver

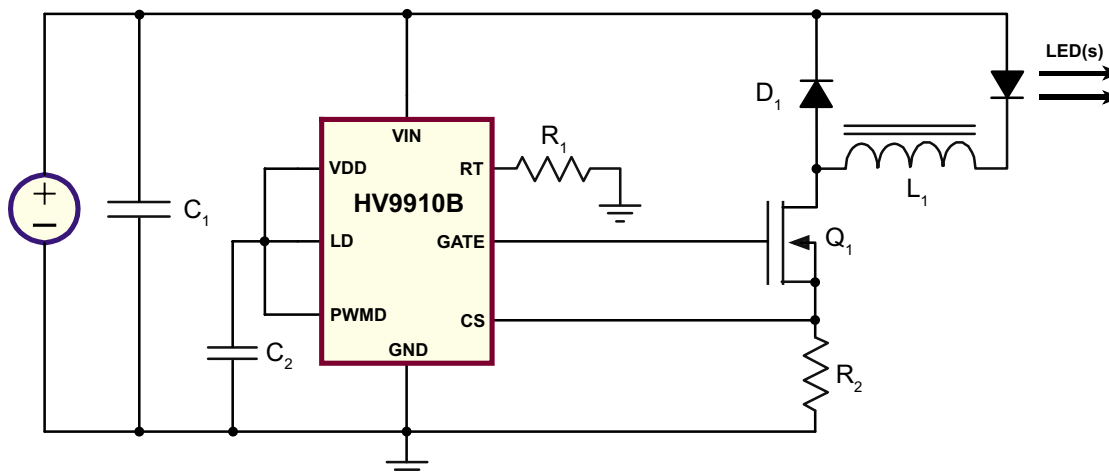
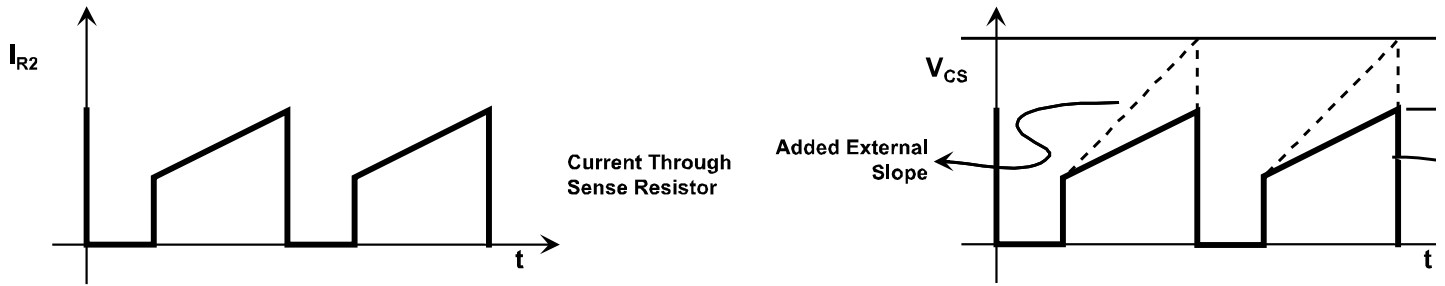

Fig. 2. Slope Compensation to Eliminate Subharmonic Oscillation



The unique design of the oscillator in the HV9910B allows the IC to be configured for either constant frequency or constant off-time based on how one resistor, connected to the RT pin, is wired. For normal operation as constant frequency converter, the resistor at the RT pin is connected to GND (Fig. 3a). For operation as a constant off-time converter, the resistor is connected between the RT and GATE pins (Fig. 3b). In both cases, the equation to determine the resistor is

given by:

$$T_{OSC}(\mu s) = \frac{R_T(k\Omega) + 22}{25}$$

For constant frequency operation T_{OSC} is set to the switching time period and for constant off-time operation, T_{OSC} is set to the required off-time.

Fig. 3a. Constant Frequency Operation

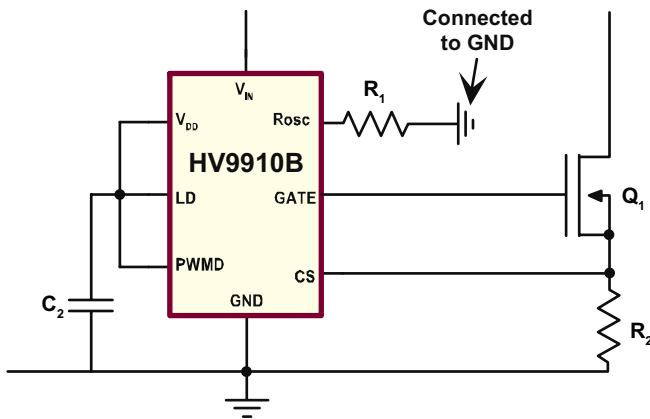

Fig. 3b. Constant Off-Time Operation

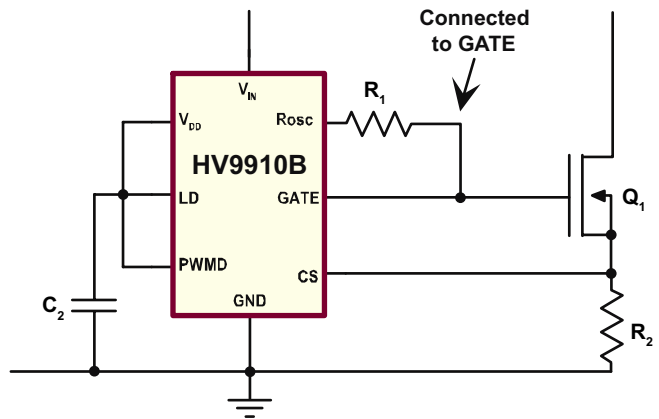
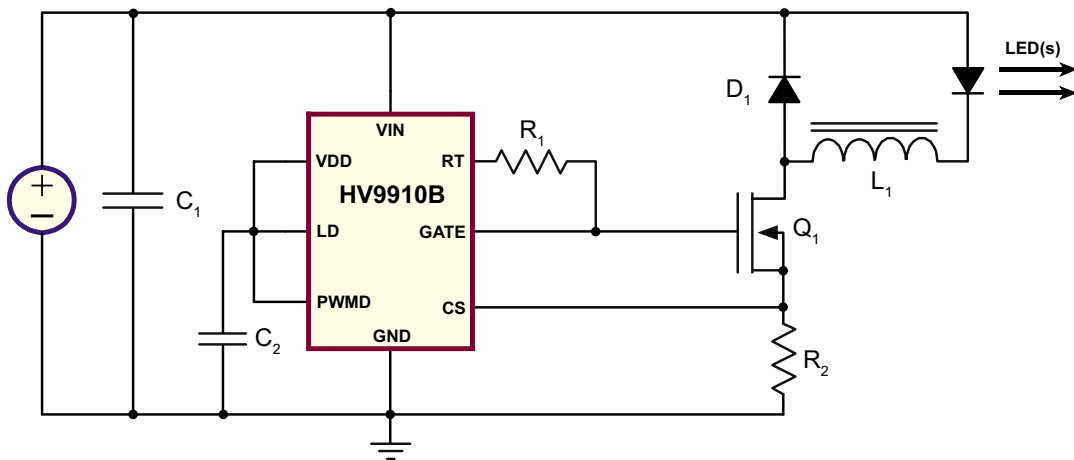

Fig. 4 Circuit Diagram



An example detailing the design of a constant off-time buck converter is shown in Fig. 4.

Input Voltage:

$$\begin{aligned} V_{IN,MIN} &= 9V \\ V_{IN,NOM} &= 12V \\ V_{IN,MAX} &= 16V \end{aligned}$$

Output Voltage (corresponds to two 1W LEDs):

$$\begin{aligned} V_{O,MIN} &= 4.6V \\ V_{O,NOM} &= 6.8V \\ V_{O,MAX} &= 8V \end{aligned}$$

LED current:

$$I_O = 350\text{mA}$$

Expected Efficiency:

$$\eta = 0.85$$

Step 1: Choose the Nominal Switching Frequency

Although the switching frequency is variable, a nominal switching frequency can be chosen. The actual frequency will vary around this nominal value based on the actual input and output conditions. A larger switching frequency will typically result in a smaller inductor, but will increase the switching losses in the circuit.

A typical switching frequency: $f_{S,NOM} = 100\text{kHz}$ is a good compromise, which corresponds to a time period of:

$$T_{S,NOM} = \frac{1}{f_{S,NOM}} = 10\mu\text{s} \quad (1)$$

Step 2: Compute the Off-Time and Resistor R1

The off-time can be calculated as:

$$t_{OFF} = \left(1 - \frac{V_{O,NOM}}{V_{IN,NOM}}\right) \times T_{S,NOM} \quad (2)$$

This off-time will then be set by the resistor R1 based on the following equation:

$$R1 = (t_{OFF} (\mu\text{s}) \cdot 25) - 22 \text{ (k}\Omega\text{)} \quad (3)$$

In this case, $t_{OFF} = 4.33\mu\text{s}$ and $R1 = 86.25\text{k}\Omega$. Note that in this case, the converter is operating at 56.7% duty cycle.

Step 3: Choose the required Inductor L1

The value of the inductor L1 will depend on the peak-to-peak

ripple desired in the output current. Assuming a 30% peak to peak ripple in the output current,

$$L1 = \frac{V_{O,NOM} \cdot t_{OFF}}{0.3 \cdot I_O} \quad (4)$$

The peak current rating of the inductor should be greater than $1.3 \times I_O$ and the rms current rating of the inductor should be at least I_O . For this example, the closest inductor available is a $330\mu\text{H}$ inductor with a 0.6A rms current rating and a 0.6A saturation current rating.

Step 4: Choose the Sense Resistor (R2)

The peak current sensed by the HV9910 corresponds to the average output current plus one half of the actual current ripple. The peak current is given by:

$$I_{PK} = I_O + \frac{V_{O,NOM} \cdot t_{OFF}}{2 \cdot L1} \quad (5)$$

The sense resistor can be then be computed as:

$$R2 = \frac{0.25}{I_{PK}} \quad (6)$$

if the internal voltage threshold is being used. Otherwise, substitute the voltage at the LD pin instead of the 0.25V in equation (6). The power rating required for the sense resistor can be computed using:

$$P_{SENSE} = (I_O)^2 \times \left(\frac{V_{O,MAX}}{V_{IN,MIN}}\right) \times R2 \quad (7)$$

For this design,

$$I_{PK} = 0.394\text{A}, R2 = 0.633\Omega, \text{ and } P_{SENSE} = 0.069\text{W}$$

Note: Capacitor C2 is a bypass capacitor. A typical value of $1\mu\text{F}$, 16V ceramic capacitor is recommended.

Step 5: Choose the FET (Q1) and Diode (D1)

The peak voltage seen by the FET is equal to the maximum input voltage. Using a 50% safety rating:

$$V_{FET} = 1.5 \cdot V_{IN,MAX} = 24\text{V} \quad (8)$$

The maximum rms current through the FET is:

$$I_{FET} = I_O \times \sqrt{\frac{V_{O,MAX}}{V_{IN,MIN}}} \quad (9)$$

Typically a FET with about 3 times the current is chosen to minimize the resistive losses in the switch. For this application, choose a 40V, 1Ω FET (TN2504 from Supertex in a SOT-89 package).

The peak voltage rating of the diode is the same as the FET. Hence:

$$V_{\text{DIODE}} = V_{\text{FET}} = 24\text{V} \quad (10)$$

The average current through the diode is:

$$I_{\text{DIODE}} = I_{\text{O}} \times \left(1 - \frac{V_{\text{O,MIN}}}{V_{\text{IN,MAX}}} \right) = 0.25\text{A} \quad (11)$$

Choose a 30V, 1A schottky diode.

Step 6: Analysis of the Switching Frequency Variation

The two extremes of the switching frequency can be approximately computed as:

$$f_{\text{S,MIN}} = \frac{1}{T_{\text{S,MAX}}} = \frac{1 - \left(\frac{V_{\text{O,MAX}}}{V_{\text{IN,MIN}}} \right)}{t_{\text{OFF}}} \quad (12)$$

$$f_{\text{S,MAX}} = \frac{1}{T_{\text{S,MIN}}} = \frac{1 - \left(\frac{V_{\text{O,MIN}}}{V_{\text{IN,MAX}}} \right)}{t_{\text{OFF}}} \quad (13)$$

In this case, the switching frequency varies from:

25kHz ($V_{\text{IN}} = 9\text{V}$, $V_{\text{O}} = 8\text{V}$) to

164kHz ($V_{\text{IN}} = 16\text{V}$, $V_{\text{O}} = 4.6\text{V}$)

Supertex inc. does not recommend the use of its products in life support applications, and will not knowingly sell them for use in such applications unless it receives an adequate "product liability indemnification insurance agreement." **Supertex inc.** does not assume responsibility for use of devices described, and limits its liability to the replacement of the devices determined defective due to workmanship. No responsibility is assumed for possible omissions and inaccuracies. Circuitry and specifications are subject to change without notice. For the latest product specifications refer to the **Supertex inc.** website: <http://www.supertex.com>.